

NUMBER
C-440133

METRIC

3RD ANGLE PROJECTION

THIS INFORMATION IS CONFIDENTIAL AND IS DISCLOSED TO YOU ON CONDITION THAT NO FURTHER DISCLOSURE IS MADE BY YOU TO OTHER THAN AMP PERSONNEL WITHOUT WRITTEN AUTHORIZATION FROM AMP (TAIWAN) LTD. DIMENSIONS IN MILLIMETERS. DO NOT SCALE PRINT.

PRINT DIST
DWN

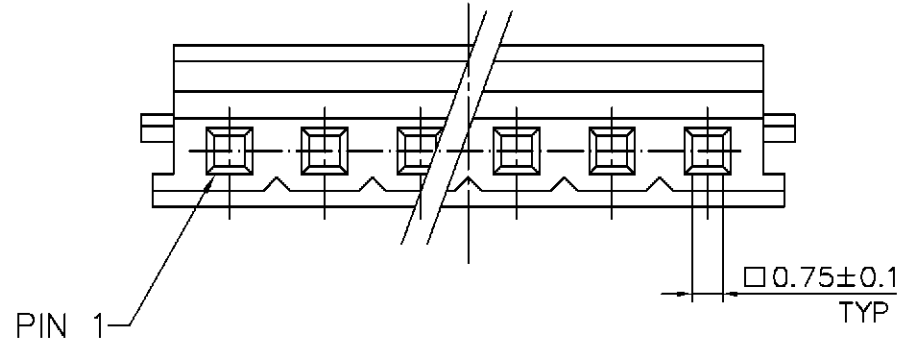
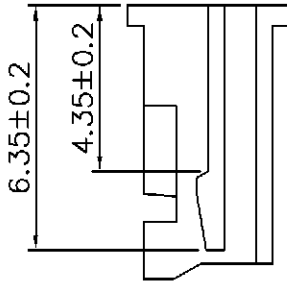
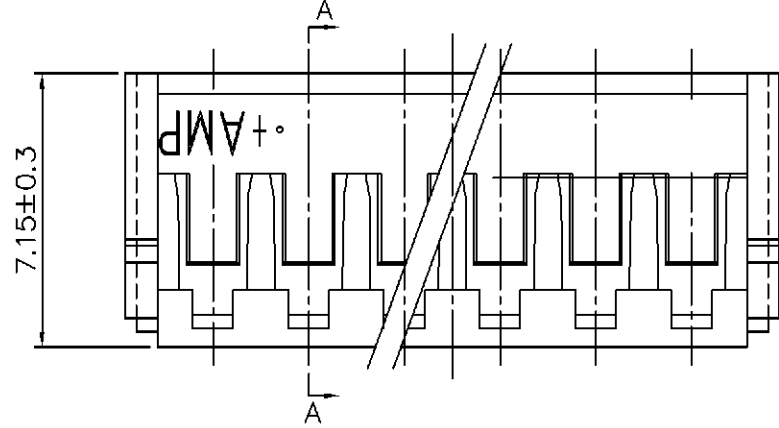
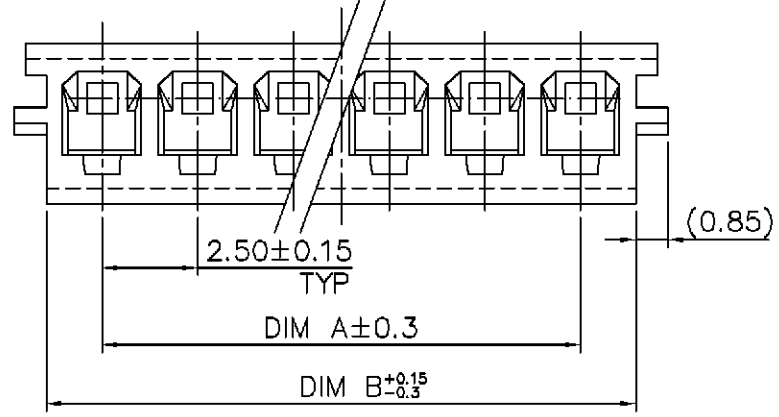
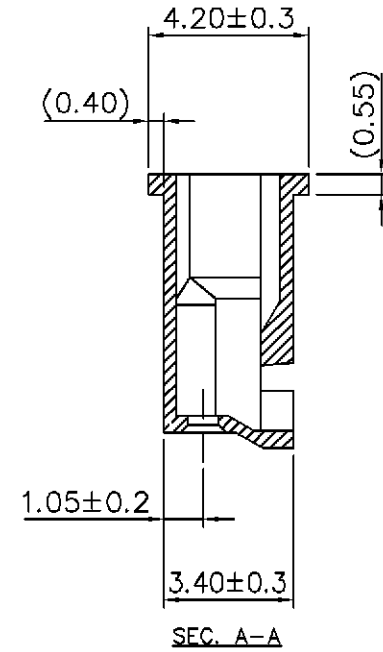

NOTE:
MATERIAL: NYLON 66 UL 94V-0, COLOR: SEE TABLE.

HSG. COLOR	DIM B	DIM A	CIRCUITS	PART NO.
YELLOW	37.9	35.00	15P	3-440133-5
	35.4	32.50	14P	3-440133-4
	32.9	30.00	13P	3-440133-3
	30.4	27.50	12P	3-440133-2
	27.9	25.00	11P	3-440133-1
	25.4	22.50	10P	3-440133-0
	22.9	20.00	9P	2-440133-9
	20.4	17.50	8P	2-440133-8
	17.9	15.00	7P	2-440133-7
	15.4	12.50	6P	2-440133-6
	12.9	10.00	5P	2-440133-5
	10.4	7.50	4P	2-440133-4
NATURAL	7.9	5.00	3P	2-440133-3
	5.4	2.50	2P	2-440133-2
	37.9	35.00	15P	1-440133-5
	35.4	32.50	14P	1-440133-4
	32.9	30.00	13P	1-440133-3
	30.4	27.50	12P	1-440133-2
	27.9	25.00	11P	1-440133-1
	25.4	22.50	10P	1-440133-0
	22.9	20.00	9P	440133-9
	20.4	17.50	8P	440133-8
	17.9	15.00	7P	440133-7
	15.4	12.50	6P	440133-6
12.9	10.00	5P	440133-5	
10.4	7.50	4P	440133-4	
7.9	5.00	3P	440133-3	
5.4	2.50	2P	440133-2	

TOLERANCES UNLESS OTHERWISE SPECIFIED: 0 PLC ± 1 PLC ± 2 PLC ± 3 PLC ± ANGLES ±	DWN O. HU 25-OCT-2002	 TYCO HOLDINGS (BERMUDA) VII LTD. TAIWAN BRANCH		
MATERIAL SEE NOTE	CHK J. CHENG 25-OCT-2002			
FINISH SEE NOTE	APVD J. WU 25-OCT-2002	2.5 MM PITCH HPI CRIMP HOUSING		
	PRODUCT SPEC 108-57099			
	APPLICATION SPEC 114-57004	LOC DW A ₃	DRAWING NO C-440133	REV B
	WEIGHT	SCALE --	SHEET 1 OF 2	

B	ADD PART NUMBERS	FZ00-0228-02	OH JC	25OCT 2002
A	REVISED	FZ00-0166-02	OH JC	26JUL 2002
LTR	REVISION RECORD	ECN	DWN CHK	DATE

PRINT DIST DW

THIS INFORMATION IS CONFIDENTIAL AND IS DISCLOSED TO YOU ON CONDITION THAT NO FURTHER DISCLOSURE IS MADE BY YOU TO OTHER THAN AMP PERSONNEL WITHOUT WRITTEN AUTHORIZATION FROM AMP (TAIWAN) LTD. DIMENSIONS IN MILLIMETERS. DO NOT SCALE PRINT.

NUMBER
C-440133

3RD ANGLE PROJECTION

METRIC

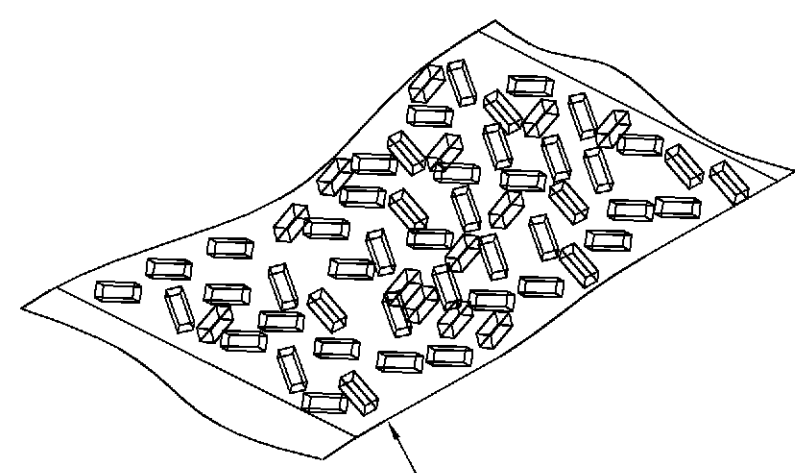
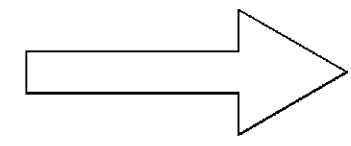
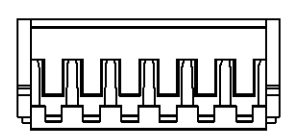

POLY BAG
127mm(L)X 203mm(W)X 0.07mm(H)

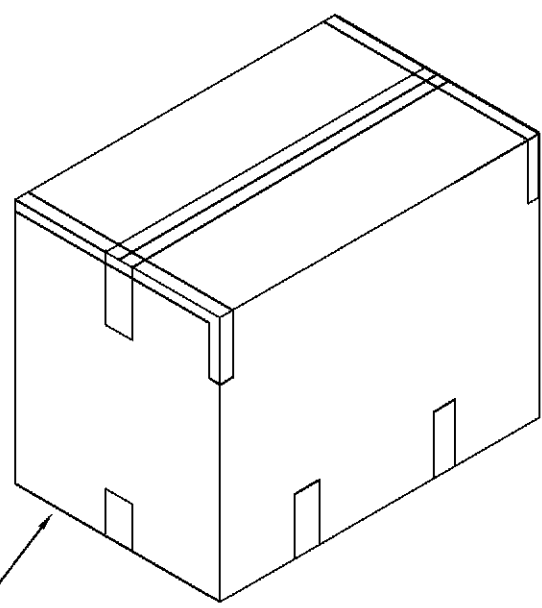
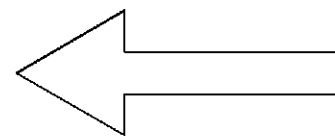
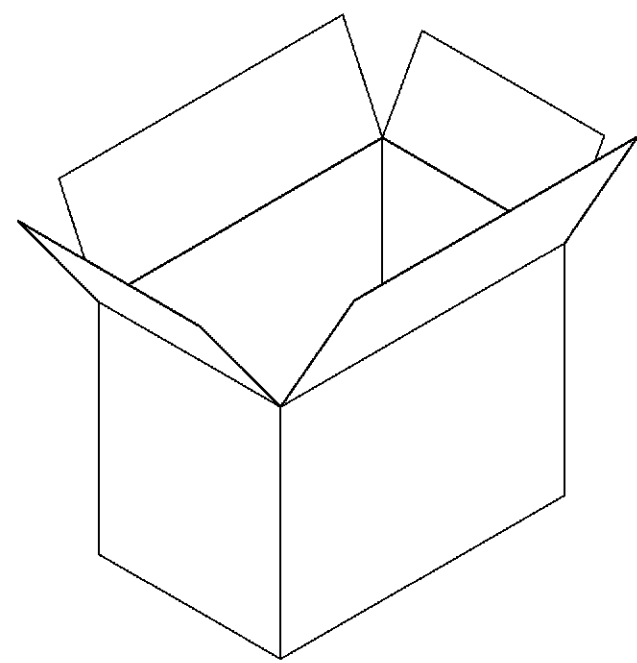
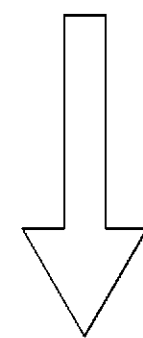

CARTON
320mm(L)X 220mm(W)X 155mm(H)
(FOR HEADER 2P~7P ONLY)
340mm(L)X 470mm(W)X 365mm(H)
(FOR HEADER 8P~15P ONLY)

15,000	1,000	15P	3-440133-5	1-440133-5
20,000	1,000	14P	3-440133-4	1-440133-4
20,000	1,000	13P	3-440133-3	1-440133-3
25,000	1,000	12P	3-440133-2	1-440133-2
25,000	1,000	11P	3-440133-1	1-440133-1
30,000	1,000	10P	3-440133-0	1-440133-0
35,000	1,000	9P	2-440133-9	440133-9
40,000	1,000	8P	2-440133-8	440133-8
8,000	1,000	7P	2-440133-7	440133-7
10,000	1,000	6P	2-440133-6	440133-6
12,000	1,000	5P	2-440133-5	440133-5
15,000	1,000	4P	2-440133-4	440133-4
20,000	1,000	3P	2-440133-3	440133-3
25,000	1,000	2P	2-440133-2	440133-2
APQ (PCS/CARTON)	PPQ (PCS/BAG)	CIRCUITS	YELLOW	NATURAL
			HOUSING COLOR	
			PART NUMBER	

TOLERANCES UNLESS OTHERWISE SPECIFIED: 0 PLC ± 1 PLC ± 2 PLC ± 3 PLC ± ANGLES ±	DWN O. HU 25-OCT-2002	 TYCO HOLDINGS (BERMUDA) VII LTD. TAIWAN BRANCH NAME 2.5 MM PITCH HPI CRIMP HOUSING
MATERIAL SEE SHEET 1.	CHK J. CHENG 25-OCT-2002	
FINISH SEE SHEET 1.	APVD J. WU 25-OCT-2002	LOC DW A ₃
	PRODUCT SPEC	DRAWING NO C-440133
	APPLICATION SPEC	REV B
	WEIGHT	SCALE --
		SHEET 2 OF 2

SEE SHEET 1.	ECN	DWN	CHK	DATE
LTR	REVISION RECORD			

8 7 6 5 4 3 2 1 CUSTOMER DRAWING